

ASSEMBLY INSTRUCTION
BATES
1600 DINING TABLE
ITEM CODE 84623

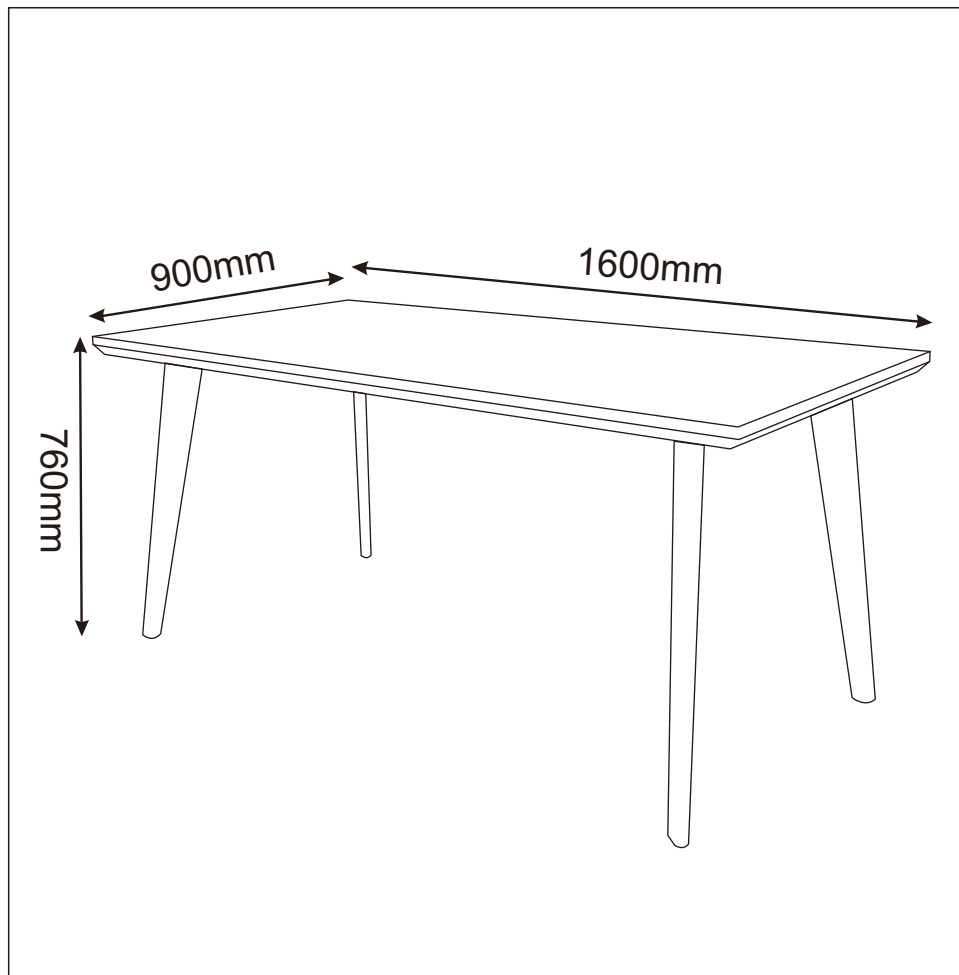

Imported by JWA Furniture Pty Ltd, Qld, Brisbane Australia.

For any assistance with assembly or for missing parts please refer to your receipt



PRE-ASSEMBLY PREPARATION

Before you start:

1. Choose a clean, level, spacious assembly area. Avoid hard surfaces that may damage the product
2. Take care when lifting. Product should be assembled as near as possible to the point of use
3. Ensure that you have all required contents for complete assembly
4. Always read the assembly instructions carefully before beginning assembly.
5. Keep all hardware parts and packaging out of reach of small children.
6. Do not over tighten the screws and bolts as this may damage the threads

		
Allow 10 min	For 2 people	Additional tools required

PARTS LIST

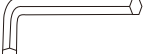
A	B	C	D
		 8x20mm	 M6
1	4	16	1

STEP 1:

- Turn over the table top (A) and put it on a protected surface
- Put the table leg (B) on the top, tighten the screw (C) with Allen (D)

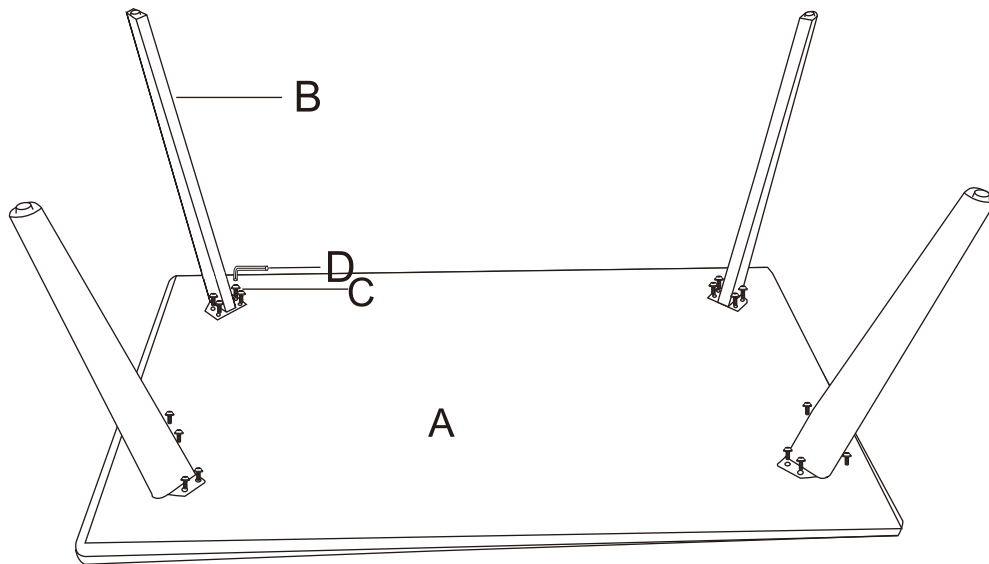

ASSEMBLY IS COMPLETE



PRODUCT CARE:

TABLE

1. When assembling your table please ensure that you have checked the contents for all relevant parts.
2. When tightening bolts make sure that they are fully tightened but not forced.
3. When moving your fully assembled table, take care when lifting and always have two people handling the table. PLEASE DO NOT DRAG THE TABLE as this will cause damage to the leg.
4. It is advisable to use approved cleaning products when cleaning the table as certain chemical based cleaners could have an adverse effect on the table finish.